

GOOOD

POWER

Lithium Battery GP-1282000-LT

USER MANUAL



IMPORTANT SAFETY INSTRUCTIONS

WARNING

Please read the user manual carefully before using the product and always take care when using this product. This product is not intended for use by young or uninformed individual without supervision. When using this product, basic precautions should always be followed.

1. DO NOT disassemble, resemble or repair the battery. Incorrect reassembly may cause combustion or electric shock.
2. If the battery is damaged, immediately stop usage!
3. DO NOT short-circuit the battery, use it near heat or water sources, or allow it to become wet.
4. DO NOT insert nails or other objects into the battery, strike it, or weld directly on the battery.
5. DO NOT use a damaged battery or operate it with damaged cables, adapters or chargers.
6. DO NOT operate this product in explosive atmospheres (i.e. flammable liquids, gases or dust) or set the unit on flammable materials (i.e. carpeting, upholstery, paper, cardboard).
7. DO NOT permit the battery to freeze. Never charge a frozen battery.
8. In case of skin or eye contact, rinse immediately with clean water and seek medical attention.
9. This product contains lithium iron batteries. When it is worn out, dispose it properly obeying the local laws and regulations.
10. Always put on insulating gloves when connecting/operating battery to application.

SAVE THESE INSTRUCTIONS

WHAT'S IN THE BOX

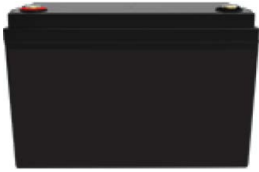

Battery



M8 Bolts



Insulating
Plugs



User
Manual

BEFORE CONNECTING

1



READ THIS MANUAL IN ITS ENTIRETY
BEFORE OPERATING THE UNIT.

2

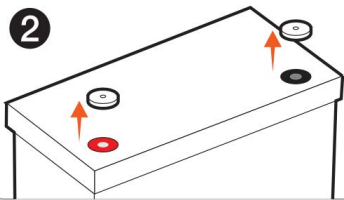

Remove the insulating
plugs on the battery.

3

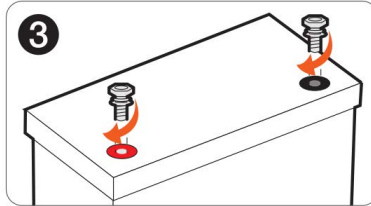

Fully screw in the M8 bolts
on to the terminals.

4

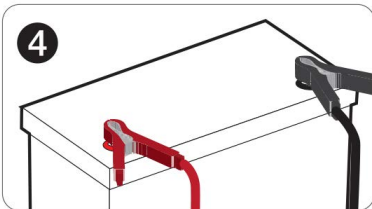

The terminals are ready to
use

STATE OF CHARGE (SOC)

This battery's capacity (or state of charge) can be roughly estimated by its resting voltage. Please refer to the following chart for percentage and its corresponding voltage.

Rest Voltage	Capacity (SOC)
13.5V	100%
13.3V	80%
13.2V	60%
13.1V	40%
12.9V	20%
12.0V	3%

RESTING VOLTAGE

Resting voltage of Lithium Iron Phosphate (LiFePO4) batteries reflects more accurate state of charge than its voltage during charging or discharging.

To measure the resting voltage, simply disconnect the battery from application or charger, and let the battery rest without loading for 30 minutes. Then you can use a multimeter to measure the voltage by connecting the probes to the battery terminals.

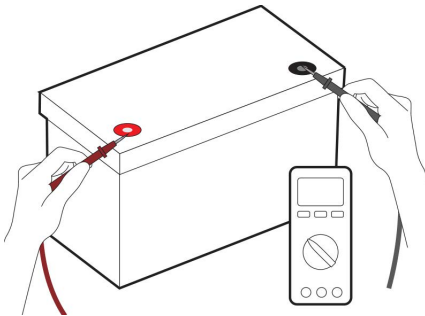

CAUTION: If you plan to connect multiple batteries together in series or parallel, please note that it is extremely important to ensure all batteries are charged to the same resting voltage before connecting. Connecting batteries without charging them to the same resting voltage may result in permanent damage.

CONNECTING MULTIPLE BATTERIES IN SERIES / PARALLEL

It is possible to connect multiple identical batteries in pairs to better match your power requirements. You can connect batteries in series to increase voltage or in parallel to increase total capacity. You can connect up to 4 batteries in Series and 2 in Parallel. See connection examples below.

To Connect in Series:

(Shown as 51.2V
200Ah Battery Pack)

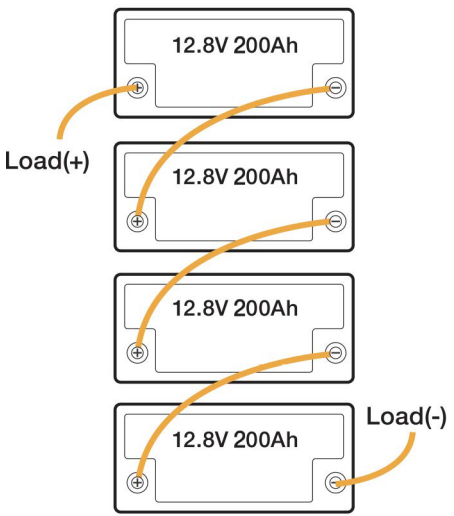

To Connect in Parallel:

(Shown as 12.8V 400Ah
Battery Pack)

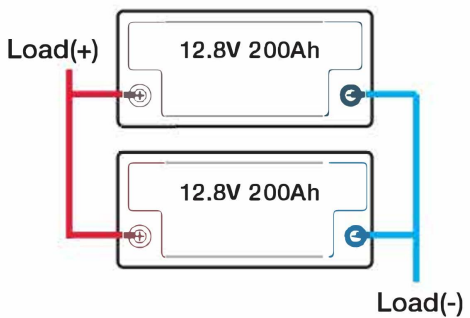

To Connect in Parallel & Series

(Shown as 25.6V 400Ah
Battery Pack)

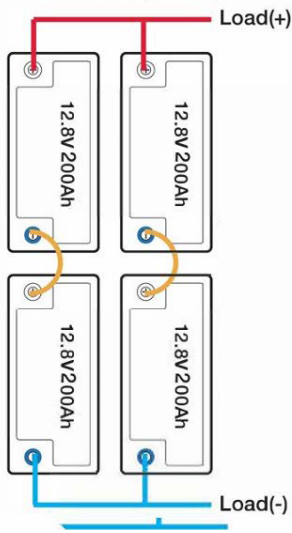

CONNECTING MULTIPLE BATTERIES IN SERIES / PARALLEL (CONT.)

CAUTION: Before connecting batteries, make sure to charge the batteries to the same resting voltage. Connecting batteries without charging them to the same resting voltage may result in permanent damage.

Use the following tips to if you plan to connect multiple cells in series / parallel.

- Only use identical batteries purchased at the same time to make connection.
- Do not connect more than 4 batteries together.
- Do not mix new and old batteries for connections.
- Choose proper cable or copper bar for battery connection. Refer to a licensed technician on the choice of cable and wire gauge.
- Balance before connecting the batteries by brings all batteries to the same resting voltage or within 0.1V difference before making the connection.
- Rebalance your batteries independently every 6 months to ensure all batteries in connection are at the exact same voltage.
- Always wear insulating gloves when connecting batteries.

STORAGE AND MAINTENANCE

- For long term storage, place the battery in a dry and ventilated room at temperature between 0°C to 30°C (or 32°F to 86°F)
- The best storage voltage for this battery is 13.2V. To prolong battery life, charge the battery back to 13.2V every 6 month to avoid over discharge when not in use.
- Do not store battery near corrosive material, fire, or heat sources.

FREQUENTLY ASKED QUESTIONS

Q: What can this battery power?

A: This battery can be used for auxiliary power in RV's trailers, motor homes, boats, cabins, sheds, gazebos, dump trailers, and where you need stored energy.

(Note: This battery is not designed for starting vehicles.)

Q: What does DOD mean?

A: DOD stands for depth of discharge, it simply refers to when the output of energy in the battery stops. For example, if you used one third of the energy, the DOD is 33%, if you used half of the energy, the DOD is 50%.

FREQUENTLY ASKED QUESTIONS

Q: What is the charge setting I should use for this battery?

A: We recommend to charge this battery through charger/inverter that comes with dedicated LiFePO4 (lithium iron phosphate) charging mode. For LiFePO4 chargers, choose preset of 4S (or 12.8V) for charging voltage and 20A current for charging current.

Q: Can I use lead acid charger/charging mode to charge this LiFePO4 battery?

A: Yes you can, but only limited to programmable lead acid charger. Please use following setting on programmable lead acid charger if LiFePO4 charging mode is not available:

Bulk / Boost phase: 13.8V

Absorption phase: 14.4V

Float phase: 0V or off

Q: Does this battery come with built-in protection circuit module (PCM)?

A: Yes, this battery came with built-in PCM with following protective features: over charge voltage/current, over discharge voltage/current, short circuit, over temperature and under temperature. Each of these protective features has their own triggering point and will stop the battery from operating once issue detected.

Q: I tried everything but it's still not working or not meeting my needs.

A: Please contact our customer service team for further assistance.

**CUSTOMER SERVICE
MORE QUESTION?**

Feel free to contact our customer service specialist:



GOOD

POWER

WWW.GOGOPOWER.CO